

4100-AB

PLEASE READ AND UNDERSTAND THESE INSTRUCTIONS CAREFULLY BEFORE INSTALLING THIS UNIT. UNIT COULD GET LOCKED PERMANENTLY BEFORE INSTALLATION IS COMPLETE

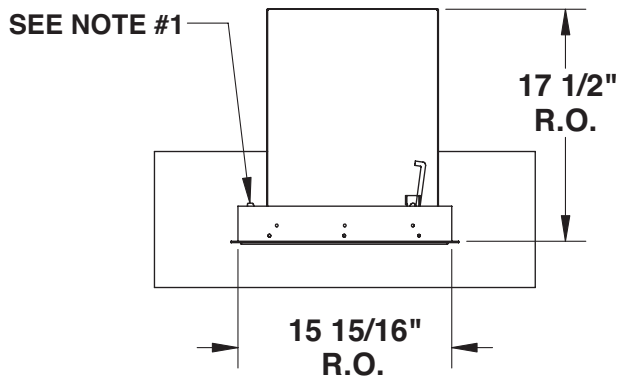

INSTALLATION INSTRUCTIONS:

1. BEHIND THE FRONT LEFT INNER RAIL IS A FINGER GRAB, LIFT IT TO RELEASE THE GATE LATCHES AND OPEN THE GATE.
2. KEEPING THE GATE OPEN, PLACE UNIT INTO ROUGH OPENING, SHIMMING WHERE NEEDED TO MAINTAIN FRAME ALIGNMENT. IN THIS PROCESS IF THE GATE WOULD HAPPEN TO CLOSE, USE THE STRING TAPED TO THE INSIDE OF THE UNIT TO PULL THE CENTER CATCH UP AND RELEASE THE GATE LATCHES.
3. INSERT #10 ANCHOR FASTENER (#10 x 2" S/S FLATHEAD WOOD SCREWS RECOMMENDED FOR WOOD FRAMING) INTO HOLES PROVIDED FOR MOUNTING. (18 HOLES ARE PROVIDED FOR FASTENING.) MAKE SURE UNIT IS KEPT SQUARE AND TRUE WHILE INSERTING THE BALANCE OF FASTENERS.
4. ONCE THE UNIT IS COMPLETELY IN PLACE, CUT THE STRING OR PUSH IT BACK INTO THE HOLE, SO THAT NO ACCESS IS GIVEN TO ANYONE TO OPEN THE COMPLETE UNIT.
5. CLOSE GATE AND THE UNIT IS PERMANENTLY CLOSED.

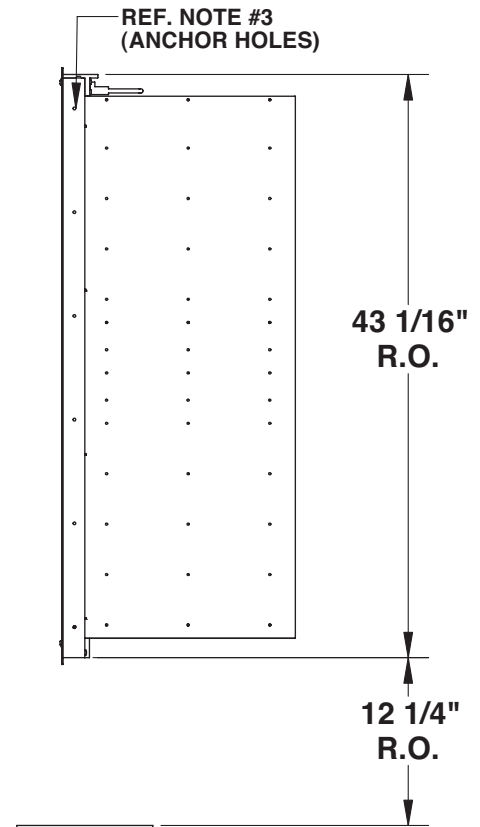
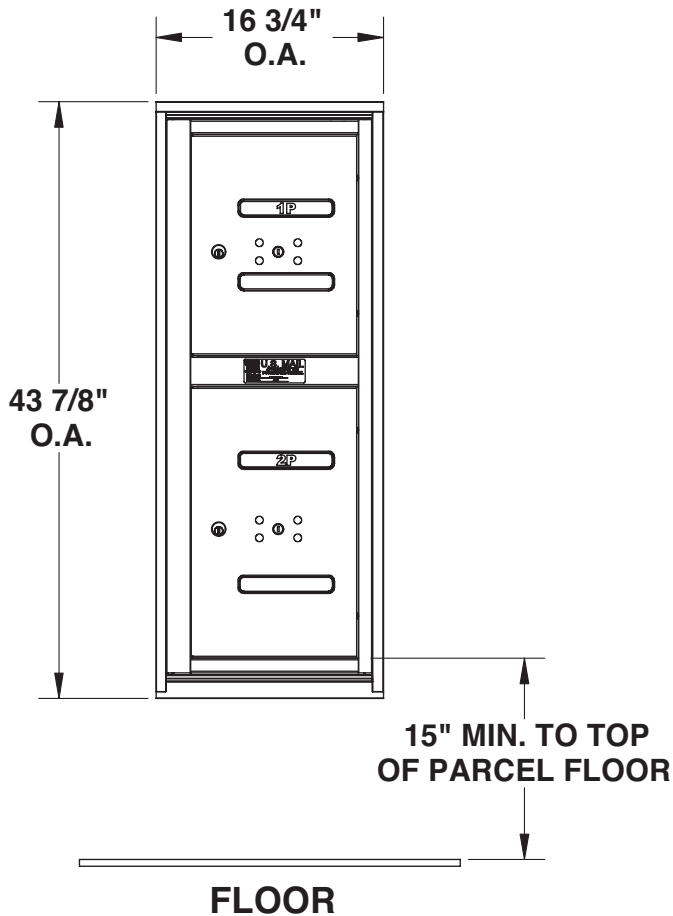

PART# 4100-AB
DWG DATE 04/29/08